

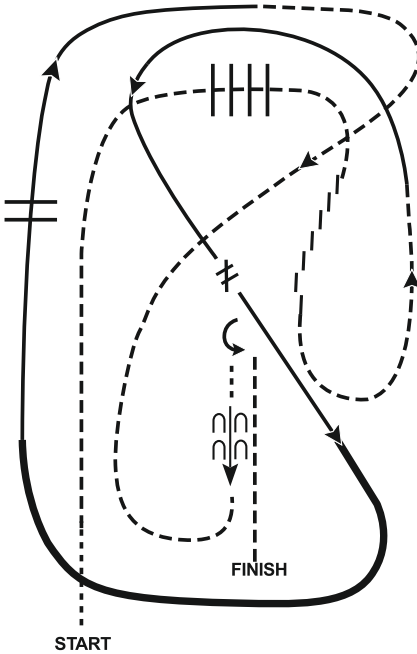

## ENGLISH VERSATILITY PATTERN

#114 - EVP1 - APHA Open

### English Versatility - Pattern 3



1. Walk with Forward Energy
2. Trot Tracking to Right
3. Trot Four Poles
4. Leg Yield Right
5. Trot Half Circle to Left
6. Left Lead Canter Arc
7. Canter Across Diagonal Changing Leads in Center (Simple or Flying)
8. Right Lead Canter Building to a Hand Gallop
9. Collect and Canter Two Rails, Cavalettis, or Small Jumps to top of pattern
10. Break to a Forward Trot Around End and Across Diagonal
11. Trot Up Center Line
12. Stop and Back
13. Walk Forward 180 Forehand Turn Left
14. Sitting Trot to exit

Walk	.....
Jog/Trot	.....
Lope/Canter	
Extended Trot	-----
Hand Gallop	=====
Leg Yield	
Change Lead	≠
Gate	⌌
Back	←←←
Judge	●
Marker	○
Sidepass	←→



YOUTH WALK TROT  
HUNT SEAT EQUITATION  
PATTERN 6

**Hunt Seat Equitation**

#46 - AWT6 - Amateur Walk-Trot

#113 - YWHS - PHCG Youth Walk Trot

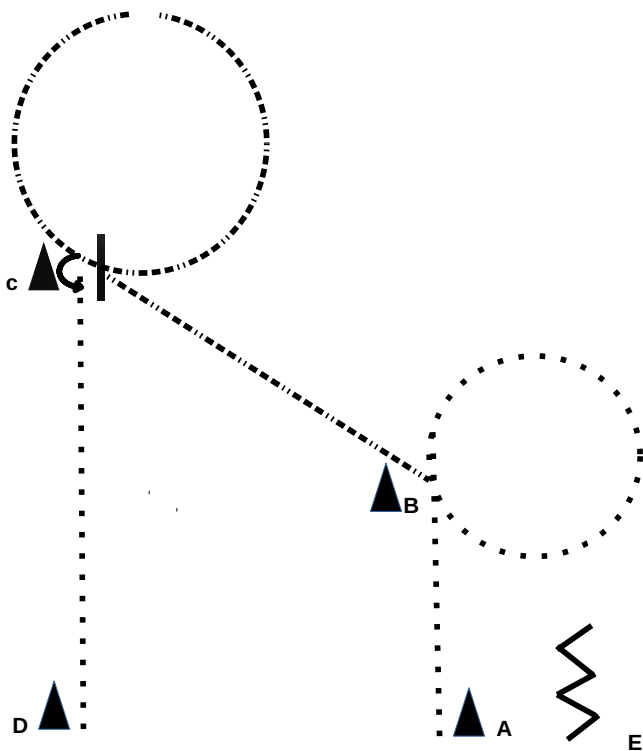

1. WALK FROM A TO B
2. WALK CIRCLE AT B
3. POSTING TROT EITHER DIAGONAL FROM B TO C
4. SITTING TROT CIRCLE AT C
5. STOP FRONTAL AT C
6. FOREHAND TURN AT C TO THE LEFT
7. WALK FROM C TO D



## HUNT SEAT EQUITATION

#44 - VEE1 - Novice Youth

#43 - NHS1 - Novice Amateur

#45 - RHSO - Rasseoffen

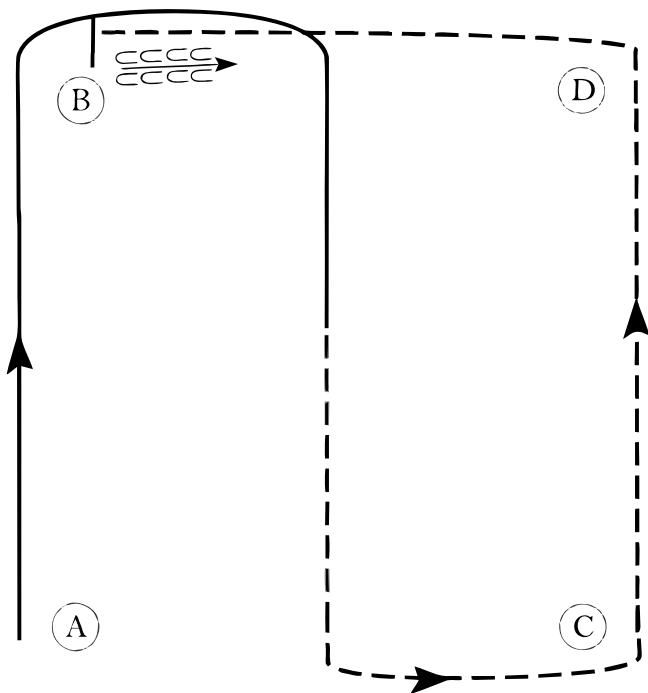

Be ready at A

1. Canter on the right lead to and around B
2. Halfway between B and C break to the trot
3. Posting trot on the right diagonal to C
4. At C change diagonals and continue to trot to D
5. At D, sitting trot to B
6. At B stop and back one horse length

Bei A bereithalten

1. Rechtsgalopp zu und um B herum
2. Auf halbem Weg zwischen B und C zum Trab durchparieren
3. Leichttraben auf der rechten Diagonale zu C
4. Bei C umsitzen und bis D weitertraben
5. Ab D aussitzen bis B
6. Bei B anhalten und eine Pferdelänge rückwärts



## HUNT SEAT EQUITATION

#105 - YEE1 - Youth

#111 - AHS1 - Amateur

#112 - AHS6 - Masters Amateur

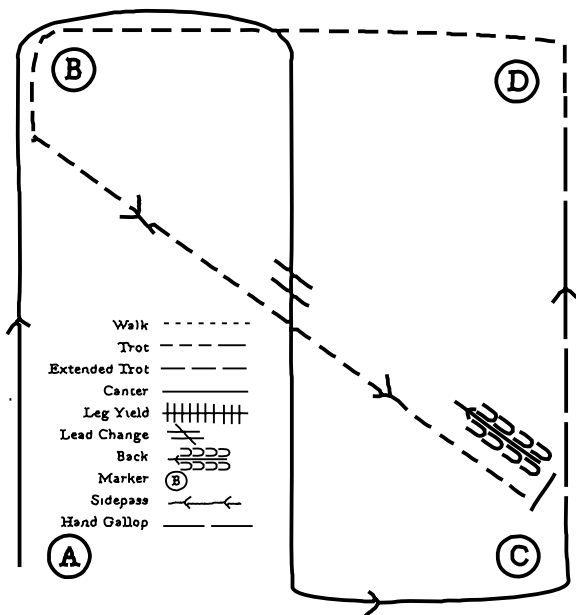

Be ready at A

1. Canter on the right lead to and around B
2. Halfway between B and C change leads
3. Canter on left lead to and around C
4. Hand gallop from C to D
5. At D, perform a posting trot on the right diagonal
6. At B, two point at the trot until halfway to C
7. Sitting trot to C
8. Stop and back one horse length at C

Bei A bereithalten

1. Im Rechtsgalopp zu und um B herum
2. auf halbem Weg zwischen B und C Galoppwechsel
3. Linksgalopp zu und C herum
4. Handgalopp von C zu D
5. Bei D Leichttraben auf der rechten Diagonale
6. Bei B leichter Sitz im Trab bis auf halben Weg zu C
7. Aussitzen im Trab zu C
8. Bei C Stop und eine Pferde länge rückwärtsrichten



## Trail in Hand

#82 - AIH3 - APHA Amateur Yearling & 2-Yr-Old

#83 - AIH4 - APHA Amateur 3-Yr-Old & Older

#84 - 530680 - NSBA Amateur

#4 TRAIL PACK #2  
WALK JOG VERSION

HORSE SHOW PATTERNS.COM

# OF LOGS : 34

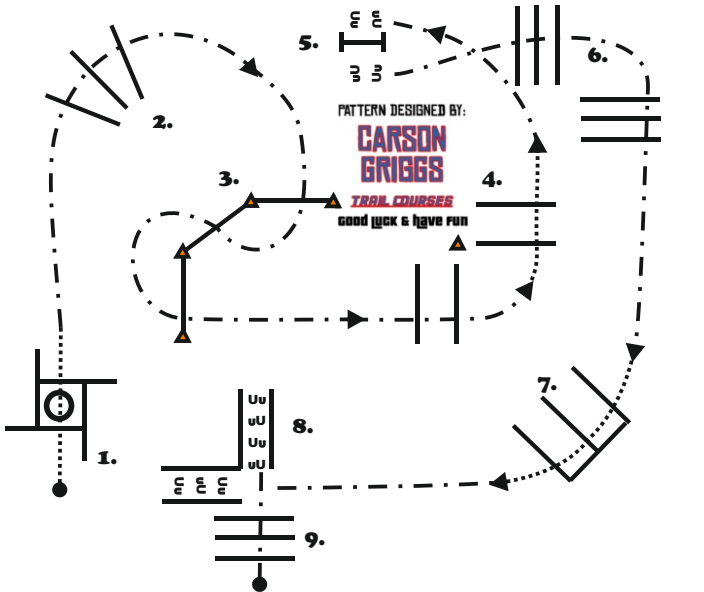

**1. WALK INTO BOX. 360 TURN RIGHT, WALK OUT**

**2. JOG OVER POLES**

**3. JOG SERPENTINE**

**4. JOG OVER, WALK OVER, JOG**

**5. OPEN GATE LEFT HAND**

**6. JOG OVER OBSTACLE #6**

**7. WALK OVER POLES**

**8. JOG INTO CHUTE. BACK „L“ CHUTE**

**9. JOG OUT TO FINISH PATTERN**

[CGTC/T/13-3.png]

©2025 HorseShowPatterns.com. All Rights Reserved.

1. Schritt in die Box, 360 Drehung nach rechts, Schritt raus

2. Jog over Stangen

3. Jog Serpentine

4. Jog over, Walk over, Jog

5. Tor linke Hand

6. Jog over Hindernis #6

7. Walk over Stangen

8. Jog in den Chute, Rückwärts L

9. Raus im Jog zum Pattern abschließen



## Trail in Hand

#127 - RT11 - Rasseoffen | #128 - IHT - APHA Yearling  
 #129 - IHT2 - APHA 2-Yr-Old | #130 - IHT4 - APHA 3 & Older  
 #131 - 530380 - NSBA Open

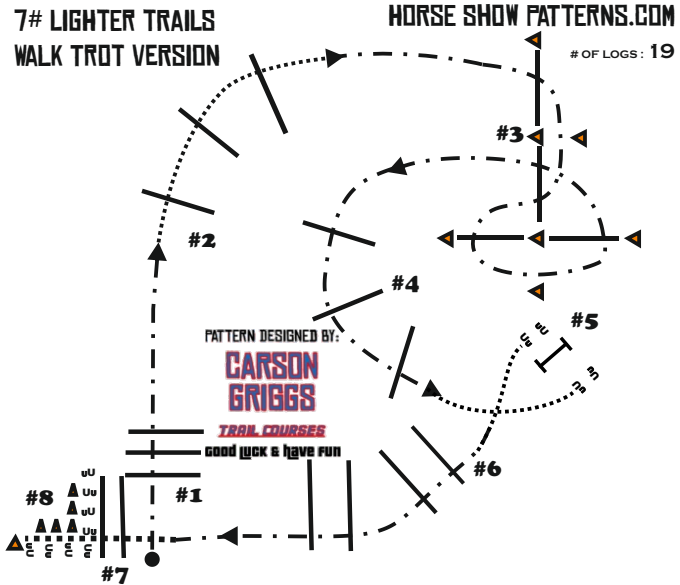

- |   |   |
|---|---|
| <ol style="list-style-type: none"> <li>1. JOG OVER FIRST 3 LOGS</li> <li>2. WALK OVER BIG FAN</li> <li>3. JOG THROUGH THE SERPENTINE</li> <li>4. JOG THE 2ND BIG FAN</li> <li>5. STOP OR BREAK TO WALK AND APPROACH GATE<br/>WORK GATE LEFT HAND</li> </ol> | <ol style="list-style-type: none"> <li>6. WALK AWAY FROM GATE, JOG OVER LOGS</li> <li>7. STOP OR BREAK TO WALK, WALK OVER LOGS</li> <li>8. WALK UP TO CONE, BACK AS SHOWN TO FINISH TEST</li> </ol> |
|---|---|

©2025 HorseShowPatterns.com. All Rights Reserved.

- |   |   |
|---|---|
| <ol style="list-style-type: none"> <li>1. Trab über die ersten 3 Stangen</li> <li>2. Schritt über großen Fächer</li> <li>3. Trab durch Serpentine</li> <li>4. Trab über 2. großen Fächer</li> <li>5. Stop oder zum Schritt durchparieren und an Tor annähern.<br/>Tor linke Hand</li> </ol> | <ol style="list-style-type: none"> <li>6. Im Schritt vom Tor weggehen Trab über Stangen</li> <li>7. Stop oder zum Schritt durchparieren, Schritt über Stangen</li> <li>8. Schritt zum Kegel, wie gezeigt rückwärtsrichten.</li> </ol> |
|---|---|



## RANCH RIDING

#123 - RWRW - Rasseoffen Walk-Trot

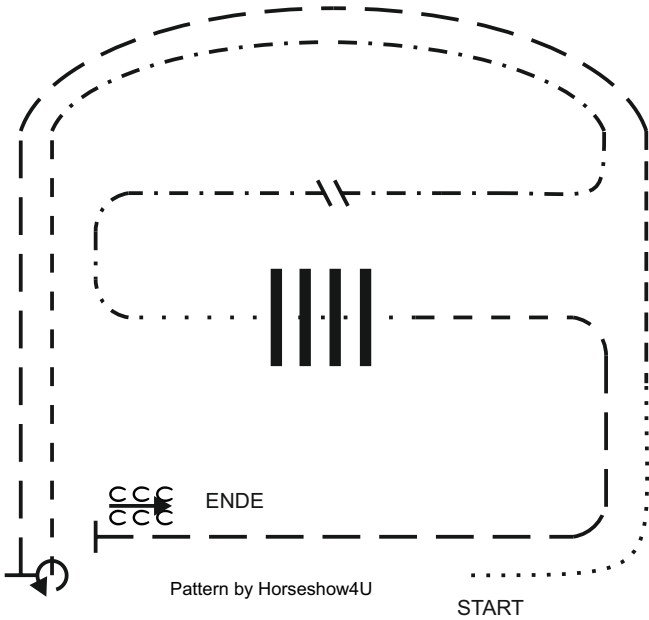

1. Walk
2. Sitting Trot
3. Extended Trot (light seat)
4. Stop, 1 1/2 turns to the right
5. Sitting Trot
6. Pick up speed at a posting trot
7. Change diagonals
8. Walk
9. Walk Over
10. Sitting Trot
11. Extended Trot (light seat or posting trot)
12. Stop and Back.

1. Schritt
2. Arbeitstrab (aussitzen)
3. Verstärkter Trab (leichter Sitz)
4. Stop, 1 1/2 Drehungen rechts
5. Arbeitstrab (aussitzen)
6. Tempo verstärken und leichttraben
7. Handwechsel (umsitzen)
8. Schritt
9. Schrittstangen
10. Arbeitstrab (aussitzen)
11. Verstärkter Trab (leichter Sitz oder leichttraben)
12. Stop und Rückwärts.



## RANCH RIDING

#115 - GRHP - Green

#116 - VRP1 - Novice Youth

#117 - NRP1 - Novice Amateur

#118 - RRIO - Rasseoffen

### Ranch Riding Pattern #12

---

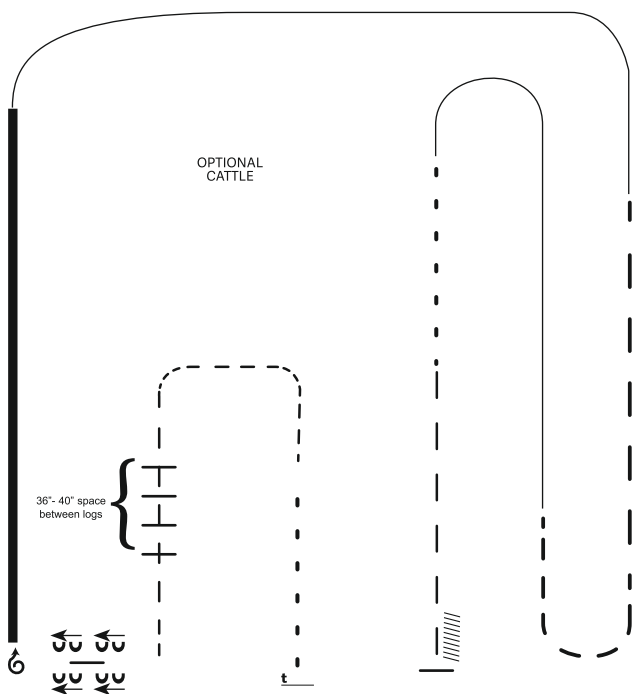

1. Walk
2. Trot
3. Trot logs
4. Side pass right
5. 1 1/2 turns right
6. Extended lope (right lead)
7. Lope right lead
8. Extended trot
9. Lope left lead
10. Walk
11. Trot
12. Stop and back



## RANCH RIDING

#119 - YRP1 - APHA Youth

#120 - IPARP1 - Class in Class Amt Ranch Riding  
(#121 - ARP1 - APHA Amateur | #122 - IRRN - IRHA NonPro)

### Ranch Riding Pattern #13

---

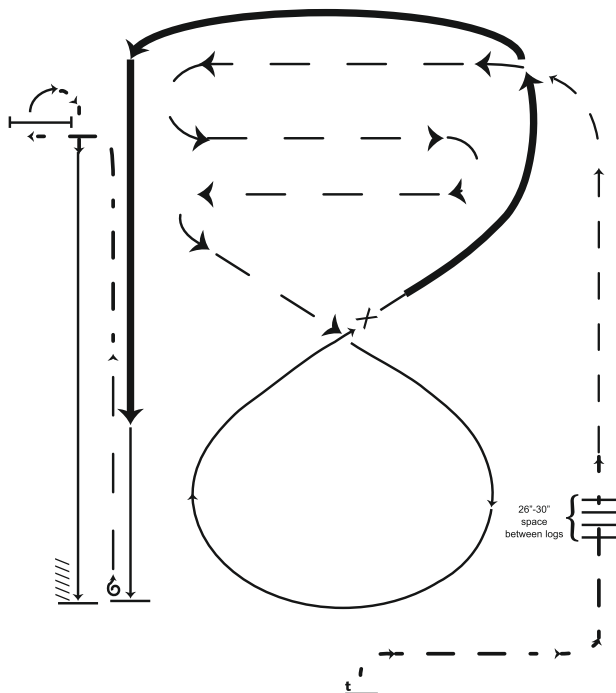

1. Walk
2. Walk over logs
3. Trot
4. Extended trot serpentine
5. Lope right lead
6. Change leads (simple or flying)
7. Extended lope (left lead), collect lope
8. Stop, 1 1/2 turn, either direction
9. Trot
10. Walk to gate
11. Right hand push gate
12. Walk, lope left lead
13. Stop and back



## RANCH RIDING

#124 - IPRHP1 - Class in Class Open Ranch Riding  
(#125 - RHP1 - APHA Open | #126 - IRRO - IRHA Open)

### Ranch Riding Pattern #9

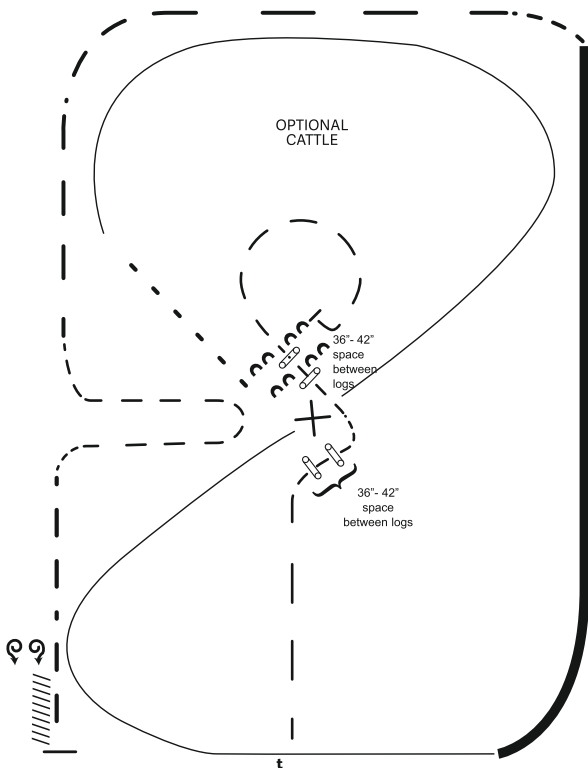

1. Trot
2. Trot two sets of logs
3. Trot circle, stop and side pass log left
4. Walk
5. Lope right lead
6. Change leads (simple or flying)
7. Lope left lead
8. Extended lope (left lead)
9. Extended trot
10. Trot
11. Walk
12. Stop and back
13. 360 degree turn each direction (either direction 1st) (L-R or R-L)

## Ranch Trail

#139 - RWRT - Rasseoffen Walk-Trot

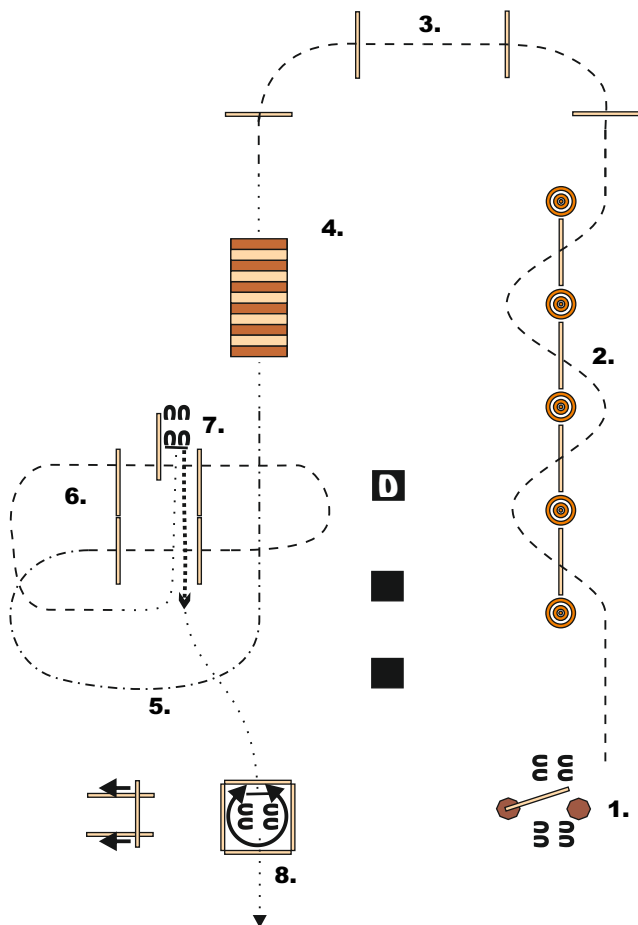

1. Gate left hand
2. Trot thru Slalom and over logs
3. Trot over logs
4. Walk over Bridge
5. Extended trot
6. Trot over logs
7. Walk to end and back out of chute
8. Walk into Box. Turn 360° left  
Dismount, turn 360° right and  
lead horse out of arena.

1. Tor linke Hand
2. Trab durch Slalom und über Stangen
3. Trab über Stangen
4. Schritt über die Brücke
5. Extended Trot
6. Trab über Stangen
7. Schritt zum Ende des Chutes und  
rückwärts aus Chute raus.
8. Schritt in die Box, 360° Drehung links  
Absitzen, 360° Drehung rechts und  
Pferd aus der Arena führen.

## Ranch Trail

- #132 - VRT1 - APHA Novice Youth  
 #133 - NRT1 - APHA Novice Amateur  
 #134 - RORT - Rasseoffen

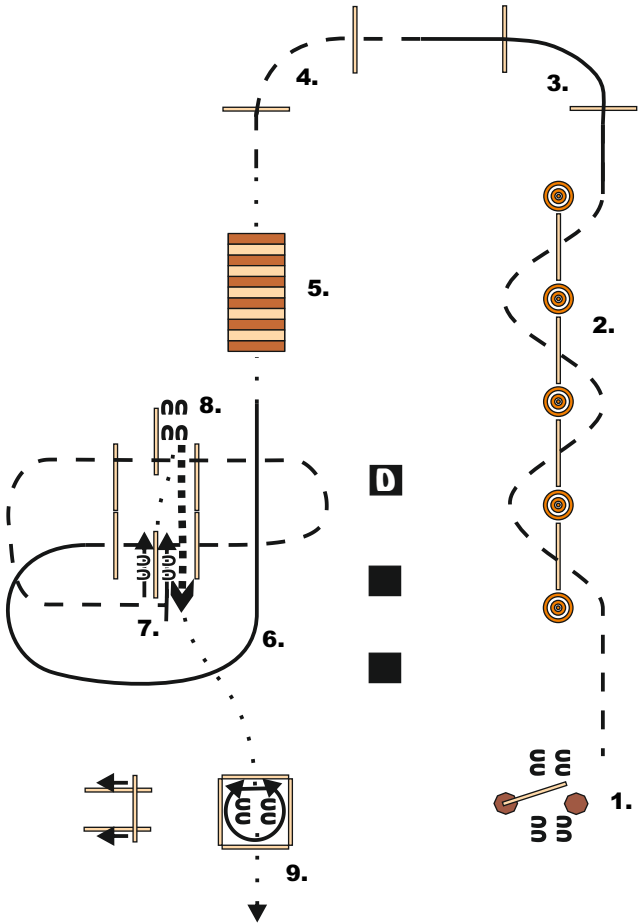

1. Gate left hand
2. Trot thru Slalom and over logs
3. Lope left lead over logs
4. Trot over Logs
5. Walk over Bridge
6. Lope right lead to logs
7. Trot over logs and stop. Sidepass left
8. Walk to end and back out of chute
9. Walk into Box. Turn 360° left Dismount, turn 360° right and lead horse out of arena.

1. Tor linke Hand
2. Trab durch Slalom und über Stangen
3. Linksgalopp über Stangen
4. Trab über Stangen
5. Schritt über die Brücke
6. Rechtsgalopp zu den Stangen
7. Trab über Stangen und Stop. Sidepass links
8. Schritt zum Ende des Chutes und rückwärts aus Chute raus.
9. Schritt in die Box, 360° Drehung links Absitzen, 360° Drehung rechts und Pferd aus der Arena führen.

## Ranch Trail

#138 - YRT1 - APHA Youth

#135 - IPART1 - Class in Class Amt Ranch Trail  
 (#136 - ART1 - APHA Amateur | #137 - IRTN - IRHA NonPro)

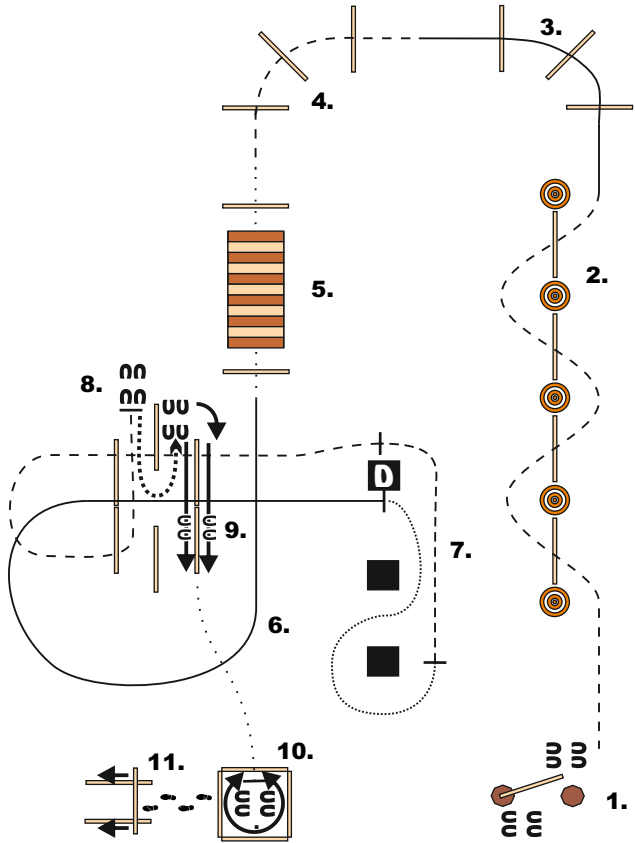

1. Gate left hand
2. Trot thru Slalom and over logs
3. Lope left lead over logs
4. Trot over Logs
5. Walk over Bridge
6. Lope right lead to and over logs
7. **Pick up rope and drag dummy through\*** slalom in walk, then trot.
8. Trot over logs into chute and stop. Back up U
9. Turn 90° on forehand, sidepass left
10. Walk into Box. Turn 360° right, turn 270° left.
11. Ground tie horse, walk to logs, move log to end, walk back to horse. Turn 270° right and lead horse out of arena

\* AMATEUR & NON PRO ONLY

1. Tor linke Hand
2. Trab durch Slalom und über Stangen
3. Linksgalopp über Stangen
4. Trab über stangen
5. Schritt über Brücke
6. Rechtsgalopp zu und über Stangen
7. **Rope aufnehmen, mit Dummy\*** durch Slalom, erst Schritt, dann im Trab
8. Trab über Stangen in den Chute & Stop, Rückwärtsrichten im U
9. 90° Vorhandwendung Sidepass links
10. Schritt in die Box, 360° Drehung rechts, 270° Drehung links
11. Ground tie, zu den Stangen gehen, Balken bewegen, zurück zum Pferd 270° Drehung rechts und Pferd Pferd aus der Arena führen.

\* NUR AMATEUR & NON PRO

## Ranch Trail

#140 - IPRT1 - Class in Class Open Ranch Trail  
 (#141 - RT1 - APHA Open | #142 - IRTO - IRHA Open)

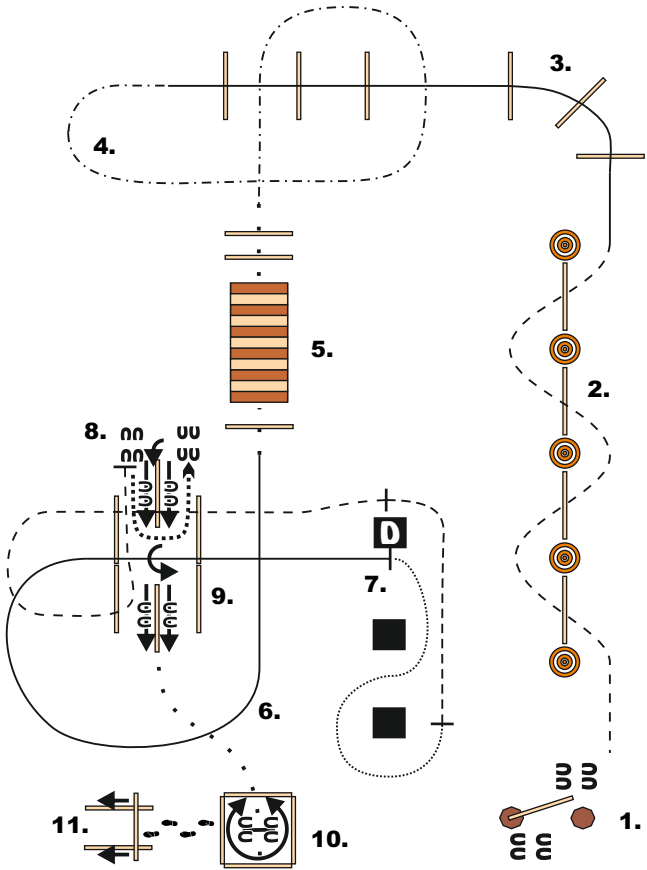

- |  |   |
|--|---|
| <ol style="list-style-type: none"> <li>1. Gate left hand</li> <li>2. Trot thru Slalom and over logs</li> <li>3. Lope left lead over logs</li> <li>4. Extended Trot</li> <li>5. Walk over Bridge</li> <li>6. Lope right lead over logs</li> <li>7. Pick up rope and drag dummy through slalom in walk, then trot.</li> <li>8. Trot over logs into chute and stop. Back up U</li> <li>9. Turn 90° on the forehand, sidepass right, turn 180 left, sidepass left</li> <li>10. Walk into Box. Turn 360° right, turn 270° left. Dismount</li> <li>11. Ground tie horse, walk to logs, move log to end, walk back to horse. Turn 270° right and lead horse out of arena</li> </ol> | <ol style="list-style-type: none"> <li>1. Tor linke Hand</li> <li>2. Trab durch Slalom und über Stangen</li> <li>3. Linksgalopp über Stangen</li> <li>4. Verstärkter Trab</li> <li>5. Schritt über Brücke</li> <li>6. Rechtsgalopp über Stangen</li> <li>7. Rope aufnehmen mit Dummy durch Slalom, erst Schritt, dann im Trab</li> <li>8. Trab über Stangen in den Chute &amp; Stop, Rückwärtsrichten im U</li> <li>9. 90° Vorhandwendung Sidepass rechts, 180° Drehung links, Sidepass links</li> <li>10. Schritt in die Box, 360° Drehung rechts, 270° Drehung links</li> <li>11. Ground tie, zu den Stangen gehen, Balken bewegen, zurück zum Pferd 270° Drehung rechts und Pferd Pferd aus der Arena führen.</li> </ol> |
|--|---|



**Reining Pattern #18**

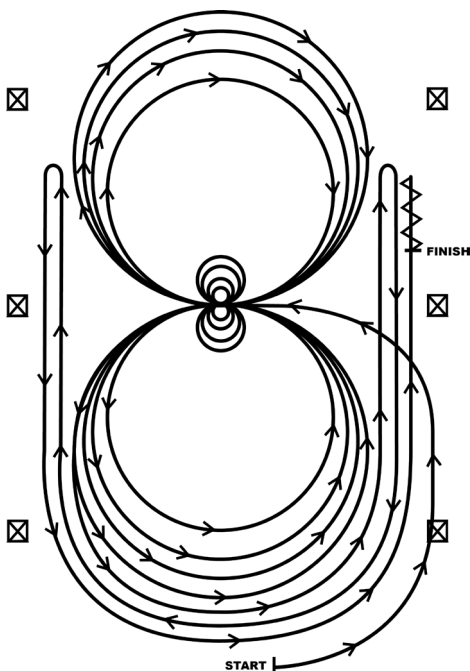

National Reining Horse Association Patterns are used with permission.  
 © 2023 National Reining Horse Association.

Begin on left lead. Continue to the center of the arena to begin the pattern facing toward the left wall or fence, without stopping or breaking gait.

1. Beginning on the left lead, complete three circles to the left: the first two circles large and fast; the third circle small and slow. Stop at the center of the arena. Hesitate.
2. Complete four spins to the left. Hesitate.
3. Beginning on the right lead, complete three circles to the right: the first two circles large and fast; the third circle small and slow. Stop at the center of the arena. Hesitate.
4. Complete four spins to the right. Hesitate.
5. Beginning on the left lead, run a large fast circle to the left, change leads at the center of the arena, run a large fast circle to the right, and change leads at the center of the arena. (Figure 8)
6. Continue around previous circle to the left but do not close this circle. Run up the right side of the arena past the center marker and do a right rollback at least twenty feet (6.09m) from the wall or fence no hesitation.
7. Continue around previous circle but do not close this circle. Run up the left side of the arena past the center marker and do a left rollback at least twenty feet (6.09m) from the wall or fence no hesitation.
8. Continue back around previous circle but do not close this circle. Run up the right side of the arena past the center marker and do a sliding stop at least twenty feet (6.09m) from the wall or fence. Back up at least ten feet (3m). Hesitate to demonstrate completion of the pattern.

Exhibitor may dismount and drop bridle to the designated judge.



YOUTH WALK TROT  
SHOWMANSHIP AT HALTER  
PATTERN 4

**Showmanship at Halter**  
**#37 - YWTS - PHCG Youth WT**

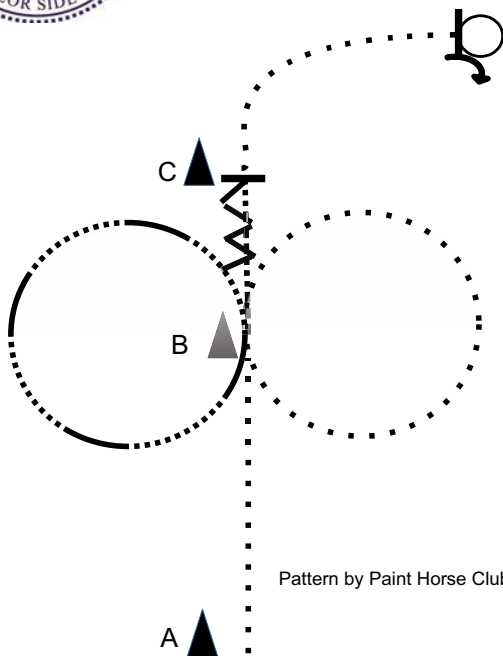

1. WALK FROM A TO B
2. AT B WALK CIRCLE TO THE RIGHT
3. AT B TROT CIRCLE TO THE LEFT
4. TROT FROM B TO C
5. STOP AT C
6. BACK UP APPROX. 1 HORSE LENGTH
7. WALK TO JUDGE
8. SET UP FOR INSPECTION
9. PERFORM  $\frac{1}{4}$  TURN



## SHOWMANSHIP AT HALTER

#30 - VSH1 - Novice Youth

#29 - NSH1 - Novice Amateur

#34 - ROSO - Rasseoffen

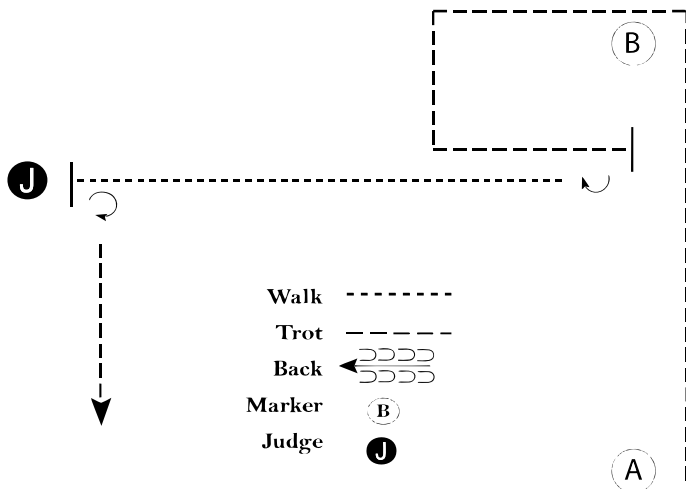

Be ready at A

1. Trot to B and trot a rectangle around B and stop even with B
2. Perform a 180 degree turn
3. Walk to the Judge and stop
4. Set up for inspection
5. When dismissed, perform a 270 degree turn and trot to exit
6. Pattern is completed once you have trotted more than one horse length away from judge

Bereithalten bei A

1. Trab zu B, Rechteck um B herumtraben und auf Höhe von B anhalten
2. 180 Grad Drehung
3. Schritt zum Richter und anhalten
4. Setup zur Inspektion
5. Wenn fertig, 270 Grad Drehung und Trab zum Ende
6. Pattern ist fertig sobald man mehr als eine Pferdelänge vom Richter weggetrabt ist.

Pattern by [horseshowpattern.com](http://horseshowpattern.com)





Youth Walk Trot  
Trail  
Pattern 6

**Trail**

- #49 - AWT4 - Amateur Walk-Trot
- #47 - RWTT - Rasseoffen Walk-Trot
- #48 - YWTT - PHCG Youth Walk Trot

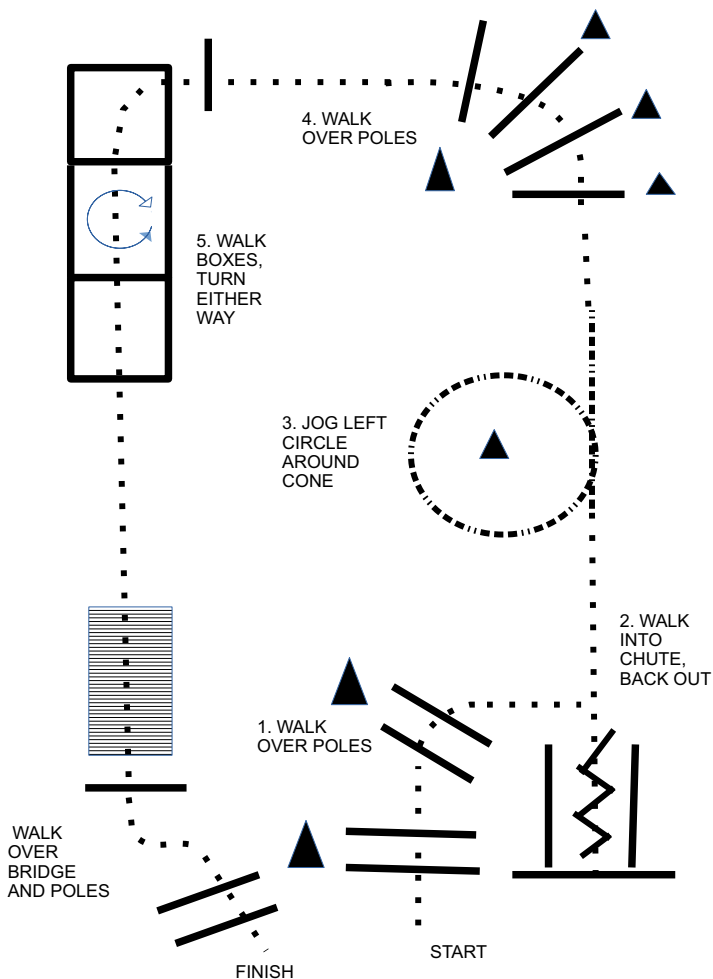



## Trail

#52 - VT1 - Novice Youth

# 53 - NT1 - Novice Amateur

#51 - GTR - Green | #50 - RTRO - Rasseoffen

### 7# LIGHTER TRAILS

HORSE SHOW PATTERNS.COM

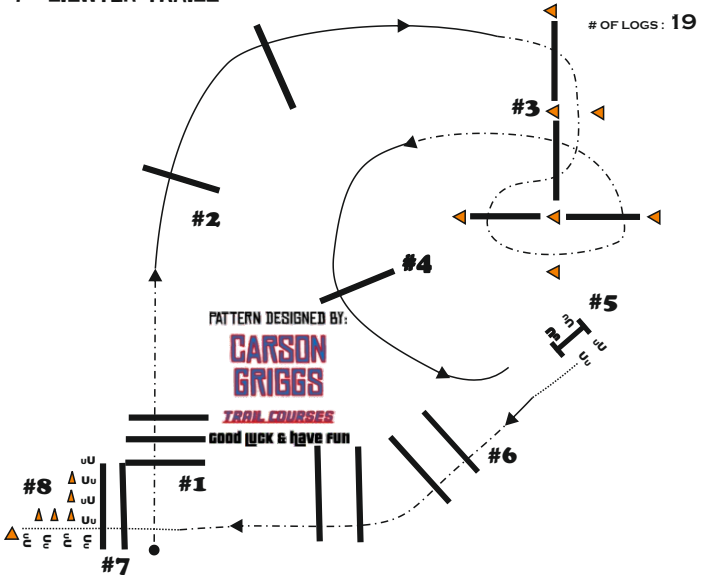

- |  |  |
|--|--|
| 1. JOG OVER FIRST 3 LOGS                                 | 6. WALK AWAY FROM GATE, JOG OVER LOGS            |
| 2. RIGHT LEAD LOPE OVER LOGS                             | 7. STOP OR BREAK TO WALK, WALK OVER LOGS         |
| 3. JOG THROUGH THE SERPENTINE                            | 8. WALK UP TO CONE, BACK AS SHOWN TO FINISH TEST |
| 4. LEFT LEAD LOPE OVER LOG                               |  |
| 5. STOP OR BREAK TO WALK & MANEUVER THRU RIGHT HAND GATE |  |

[CGTC/T/7-1.png]

©2025 HorseShowPatterns.com. All Rights Reserved.

- |   |  |
|---|--|
| 1. Trab über die ersten 3 Stangen   | 6. Schritt vom Tor weg, Trab über Stangen                    |
| 2. Rechtsgalopp über Stangen  | 7. Stop oder zum Schritt durchparieren, Schritt über Stangen |
| 3. Trab Serpentine  | 8. Schritt bis zum Kegel. Wie gezeigt rückwärtsrichten.      |
| 4. Linksgalopp über Stange  |  |
| 5. Anhalten oder durchparieren zum Schritt und dann Tor mit rechter Hand. |  |

## Trail

#89 - PAT1 - Class in Class Amateur Trail  
 (#90 - AT1 - APHA Amateur | #91 - 535600 - NSBA Amateur)  
 #95 - AT6 - APHA Masters Amateur

#4 TRAIL PACK #2 B

HORSE SHOW PATTERNS.COM

# OF LOGS : 31

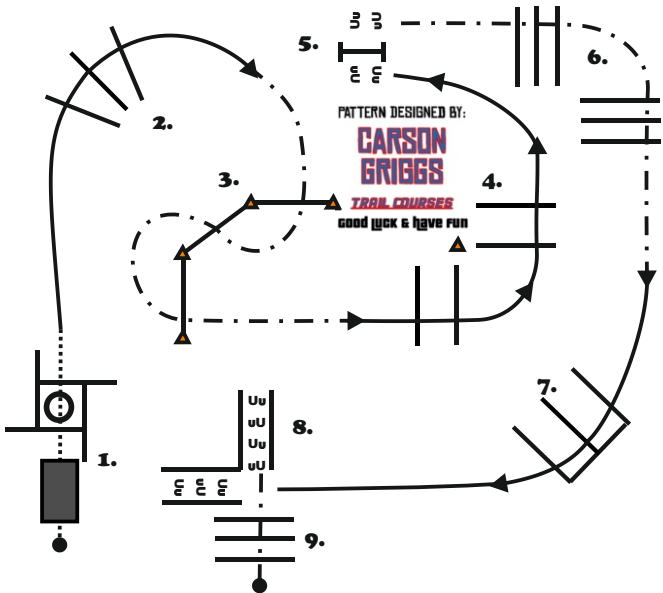

1. BRIDGE, WALK INTO BOX. 360 EITHER WAY, WALK OUT
2. RIGHT LEAD LOPE FANNED LOG
3. JOG SERPENTINE
4. LOPE LEFT LEAD OBSTACLE #4
5. RIGHT HAND GATE

6. JOG OVER POLES AS SHOWN
7. RIGHT LEAD LOPE OVER POLES
8. LOPE INTO CHUTE. BACK „L“ CHUTE
9. JOG OUT OF CHUTE AND OVER LOGS TO FINISH PATTERN

[CGTC/T/13-3.png]

©2025 HorseShowPatterns.com. All Rights Reserved.

- |   |  |
|---|--|
| <ol style="list-style-type: none"> <li>1. Brücke, Schritt in die Box, 360° in eine Richtung, Schritt raus</li> <li>2. Rechtsgalopp über Stangenfächer</li> <li>3. Trab Serpentine</li> <li>4. Linksgalopp Hindernis #4</li> <li>5. Tor rechte Hand</li> </ol> | <ol style="list-style-type: none"> <li>6. Trab über Stangen wie gezeigt</li> <li>7. Rechtsgalopp über Stangen</li> <li>8. Galopp in den Chute, Rückwärts L</li> <li>9. Zum Abschluss Chute im Trab über Stangen verlassen</li> </ol> |
|---|--|

## Trail

#85 - YT1 - APHA Youth

#86 - POTRL2 - Class in Class Junior Trail

(#87 - TRL2 - APHA Junior | #88 - 530301 - NSBA Junior)

#4 TRAIL PACK #2 B

HORSE SHOW PATTERNS.COM

# OF LOGS : 27

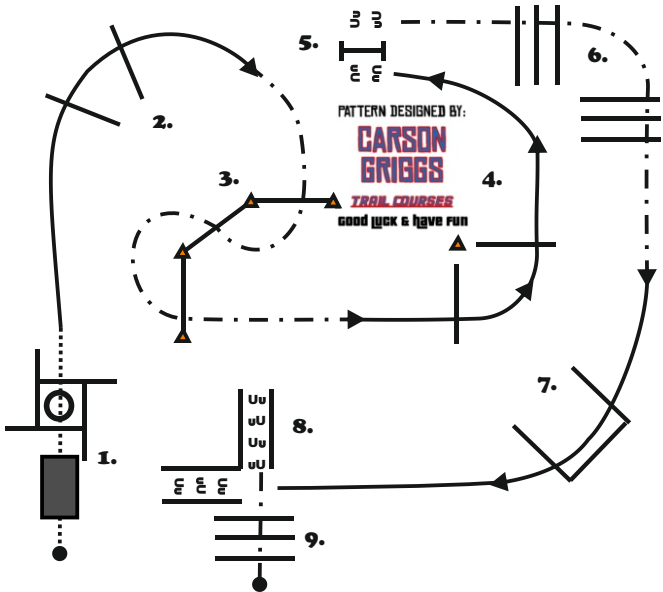

**1. BRIDGE, WALK INTO BOX. 360 EITHER WAY, WALK OUT**

**2. RIGHT LEAD LOPE FANNED LOG**

**3. JOG SERPENTINE**

**4. LOPE LEFT LEAD OBSTACLE #4**

**5. RIGHT HAND GATE**

**6. JOG OVER POLES AS SHOWN**

**7. RIGHT LEAD LOPE OVER POLES**

**8. LOPE INTO CHUTE. BACK „L“ CHUTE**

**9. JOG OUT OF CHUTE AND OVER LOGS TO FINISH PATTERN**

[CGTC/T/13-3.png]

©2025 HorseShowPatterns.com. All Rights Reserved.

1. Brücke, Schritt in die Box, 360° in eine Richtung, Schritt raus
2. Rechtsgalopp über Stangenfächer
3. Trab Serpentine
4. Linksgalopp Hindernis #4
5. Tor rechte Hand

6. Trab über Stangen wie gezeigt
7. Rechtsgalopp über Stangen
8. Galopp in den Chute, Rückwärts L
9. Zum Abschluss Chute im Trab über Stangen verlassen

## Trail

#92 - POTRL3 - Class in Class Senior Trail  
 (#93 - TRL3 - APHA Senior | #94 - 530302 - NSBA Senior)

#4 TRAIL PACK #2

HORSE SHOW PATTERNS.COM

# OF LOGS : 34

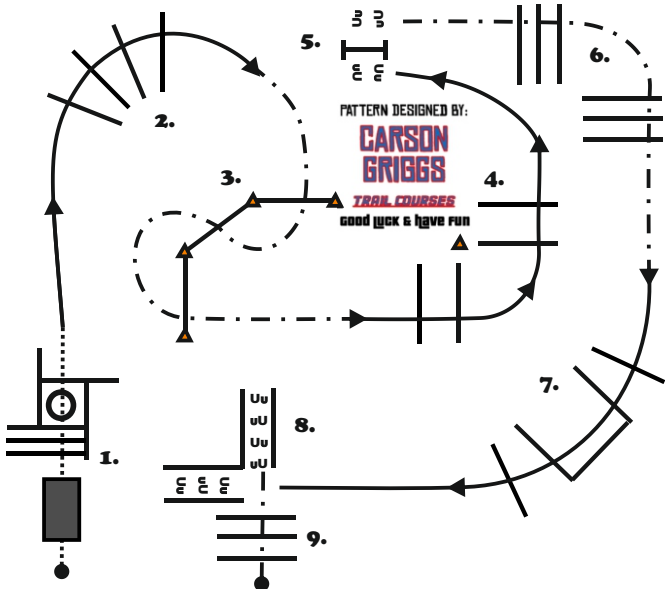

1. BRIDGE, WALK INTO BOX. 360  
EITHER WAY, WALK OUT

2. RIGHT LEAD LOPE FANNED LOGS

3. JOG SERPENTINE

4. LOPE LEFT LEAD OBSTACLE #4

5. RIGHT HAND GATE

6. JOG OVER POLES AS SHOWN

7. RIGHT LEAD LOPE OVER POLES

8. LOPE INTO CHUTE. BACK „L“  
CHUTE

9. JOG OUT OF CHUTE AND OVER  
LOGS TO FINISH PATTERN

[CGTC/T/13-3.png]

©2025 HorseShowPatterns.com. All Rights Reserved.

1. Brücke, Schritt in die Box, 360° in eine Richtung, Schritt raus
2. Rechtsgalopp über Stangenfächer
3. Trab Serpentine
4. Linksgalopp Hindernis #4
5. Tor rechte Hand

6. Trab über Stangen wie gezeigt
7. Rechtsgalopp über Stangen
8. Galopp in den Chute, Rückwärts L
9. Zum Abschluss Chute im Trab über Stangen verlassen



YOUTH WALK TROT  
WESTERN HORSEMANSHIP  
PATTERN 6

**Western Horsemanship**

#165 - AWT3 - Amateur Walk-Trot

#168 - YWTH - PHCG Youth Walk Trot

#167 - RWTH - Rasseoffen Walk-Trot

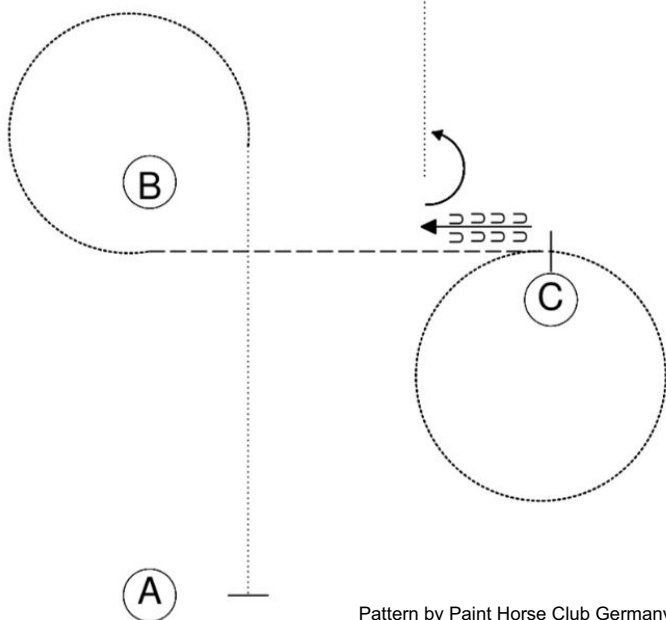

Pattern by Paint Horse Club Germany

BE READY AT A

1. WALK TO B
2. AT B WALK 3/4 CIRCLE AROUND B
3. TROT TO C. WALK CIRCLE AROUND C
4. STOP AT C AND BACK UP APPROX. 1 HORSE LENGTH
5. PERFORM A 90 DEGREE TURN TO THE LEFT
6. WALK OUT AND FOLLOW THE INSTRUCTION OF YOUR RING STEWARD



## WESTERN HORSEMANSHIP

#164 - YH1 - Youth

#163 - AH1 - Amateur

#166 - AH6 - Masters Amateur

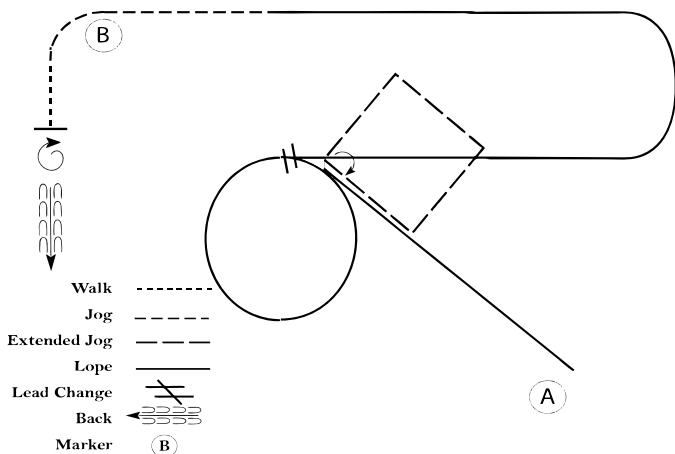

Be ready at A

1. Lope left lead to center of pattern
2. Break to a jog in a square as shown
3. Stop in center of pattern and perform a right rollback
4. Lope a right lead circle as shown
5. As you close circle, change leads (simple or flying)
6. Lope with a moderate increase in speed towards B as shown.
7. Break to the jog when 20 feet (6m) from B. Jog around B
8. Break to the walk and walk one horse length
9. Stop and perform a 540 degree turn right.
10. Back and hesitate
11. Exit at a walk or jog.

Follow the instructions of your ring steward

Bei A bereithalten

1. Linksgalopp zur Mitte des Patterns
2. Durchparieren und Viereck im Trab wie gezeigt
3. Stop in der Mitte und Rollback nach rechts
4. Volte im Rechtsgalopp wie gezeigt
5. Beim Schließen der Volte Galoppwechsel (einfach oder fliegend)
6. In moderater Geschwindigkeit zu C galoppieren
7. 6m vor B zum Trab durchparieren. Trab um B herum.
8. Durchparieren zum Schritt und eine Pferdelänge im Schritt
9. Stop und 540 Grad Drehung rechts
10. Rückwärts und verharren
11. Im Schritt oder Trab die Arena verlassen

Den Anweisungen des Ringstewards folgen



## WESTERN RIDING

#170 - GWR - Green

# 173 - ROWR - Rasseoffen

Green Western Riding Pattern #6

---

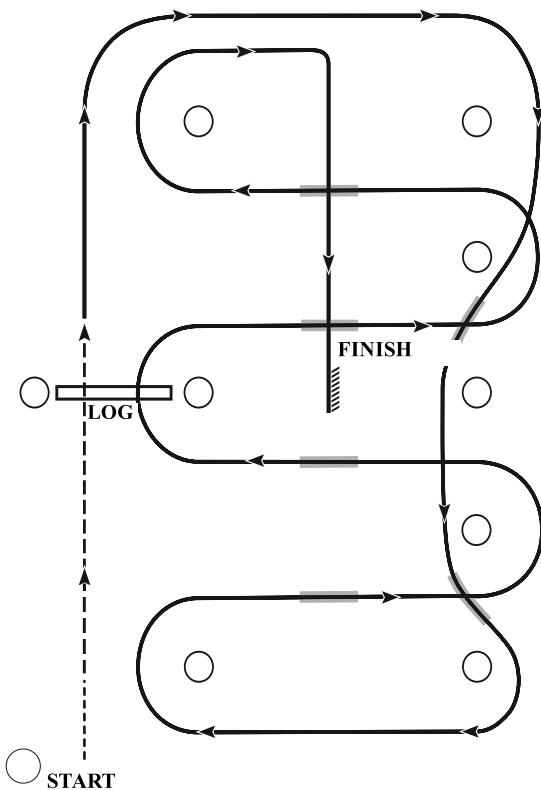

1. Walk at least 15 feet from start cone to the first marker, as drawn, transition to jog, jog over log.
2. Transition to right lead and lope around end.
3. First line change.
4. Second line change, lope around end of arena
5. First crossing change.
6. Second crossing change.
7. Lope over log.
8. Third crossing change.
9. Fourth crossing change.
10. Lope up the center, stop and back.



## WESTERN RIDING

#171 - AWR1 - Amateur

# 172 - WR1 - Open

### Western Riding Pattern #6

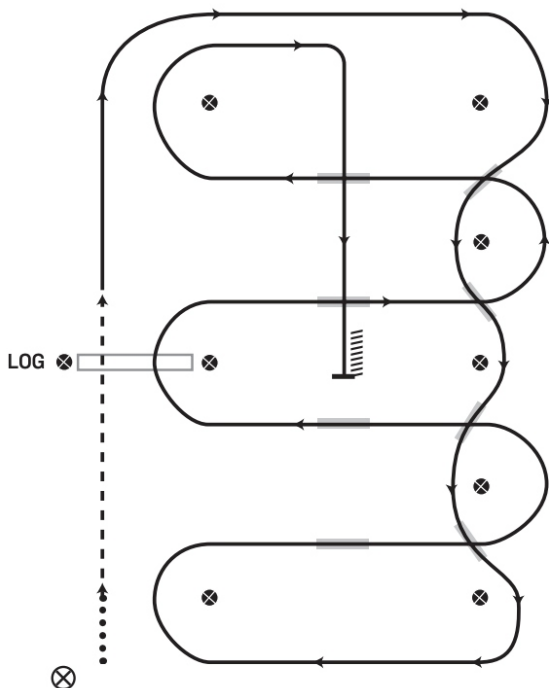

1. Walk at least 15 feet from start cone to the first marker, as drawn, transition to jog, jog over log
2. Transition to right lead & lope around end
3. First line change
4. Second line change
5. Third line change
6. Fourth line change lope around the end of arena
7. First crossing change
8. Second crossing change
9. Lope over log
10. Third crossing change
11. Fourth crossing change
12. Lope up the center, stop & back



## WESTERN VERSATILITY PATTERN

#169 - WVP1 - APHA Open

Western Versatility - Pattern 4

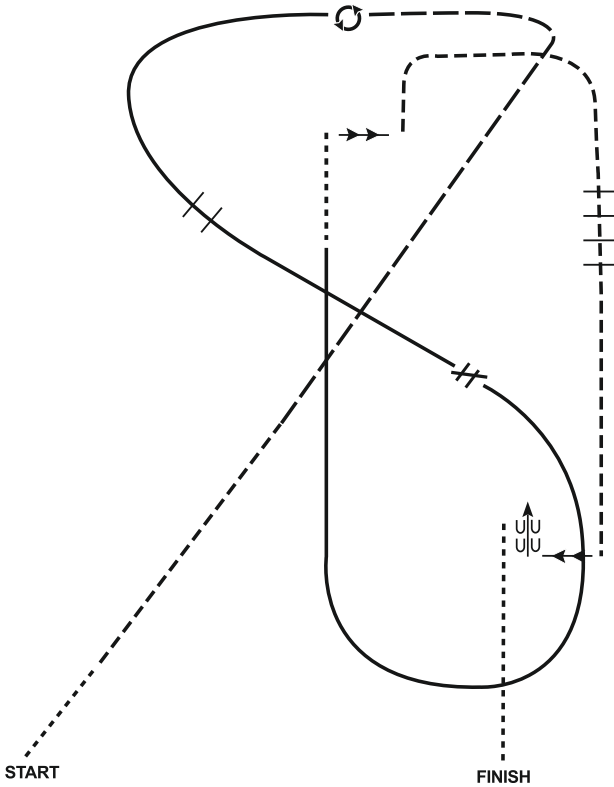

- |                                    |                         |
|------------------------------------|-------------------------|
| 1. Walk                            | 9. Break to Walk        |
| 2. Jog                             | 10. Sidepass Right      |
| 3. Extended Jog                    | 11. Jog                 |
| 4. Stop 360 Left                   | 12. Jog over Four Poles |
| 5. Left Lead                       | 13. Sidepass Pole Right |
| 6. Lope Two Poles                  | 14. Back                |
| 7. Change Leads (Simple or Flying) | 15. Walk to Exit        |
| 8. Lope Right Lead Up Center       |                         |

